





## The ideal small business compressor

Atlas Copco compressors are legendary for their reliability and efficiency. That is why our G series has long been the preferred air solution for small and medium-sized businesses. The G 2-7, the G 7L-15, and the G 15L-22 simply check all the boxes.

### ✓ Built-in reliability

- Atlas Copco's patented rotary screw element allows for continuous operation.
- The complete unit is designed to run reliably at ambient temperatures of up to 46°C/115°F.

### ✓ Top performance

- Silent operation thanks to belt-driven element.
- Full feature version available with integrated refrigerant dryer and filters.

### ✓ Easy installation & maintenance

- Available in multiple configurations – including floor or tank-mounted and with or without integrated dryer.
- Extremely small footprint and cooling air discharge from the top allow for placement against a wall or even in a corner.
- Main components, oil separator and filter are easily accessible.

### ✓ Robust and efficient compression element

Atlas Copco's trusted rotary screw element offers high free air delivery and supreme reliability.



# Next-generation connectivity

The revolutionary Elektronikon® Nano™ gives you ease of use, a reliable performance and maximum efficiency:

- Premium quality, intuitive display.
- Remote control and monitoring.
- Real-time service alerts on your computer or mobile device.



## Delayed Second Stop (DSS)

The Nano's DSS feature stops the compressor's motor whenever possible. The controller maintains the desired system pressure while minimizing the motor run time to keep your energy consumption at a minimum.

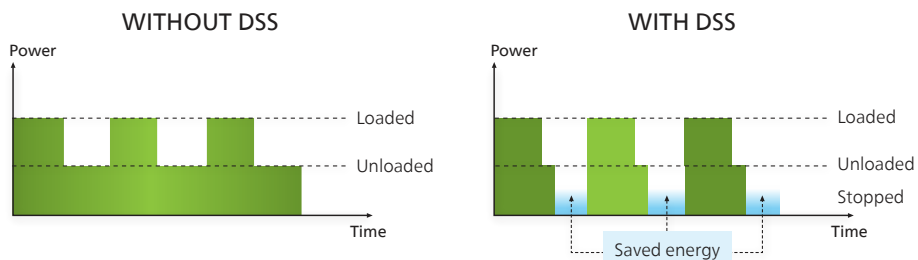

## SMARTLINK control & monitoring

Why walk over to your compressor when you can just manage it on your mobile device with our SMARTLINK app?

- **REMOTE CONTROL:** Turn your G on/off, select unload/load pressure and pressure bands, and set a weekly schedule via Bluetooth®.
- **MONITORING & OPTIMIZATION:** Monitor your compressor's pressure, temperature, running hours and operation mode from anywhere.
- **ELIMINATE ENERGY WASTE:** Run a leakage detection program and find energy losses in your air system.



Download  
SMARTLINK now!



## The always improving compressor

With Nano-controlled G, you don't miss out on innovations, even after you have bought your compressor. As new features become available and if you agree, they will be sent automatically and securely to your compressor. The result: your G never gets outdated.





## Zero hassle, zero worries compressors



### High reliability

- 100% continuous duty cycle.
- Up to 46°C/115°F ambient temperatures.



### Low maintenance

- Easy access for maintenance.
- Quality components.
- Long service interval of 4000 hours.



### Silent operation

- Belt-driven element.
- Reduced noise levels and low vibration.



### Full Feature (FF)

- Integrated refrigerant air dryer.
- In-line air filters.



### Environmentally friendly

- Reduced energy consumption.
- Low CO<sub>2</sub> emissions.

ATLAS COPCO  
G SERIES  
—  
A TRUSTED  
PARTNER



### **G 15L-22** **The robust, economical compressor**

- Reliable performance with a 100% continuous duty cycle in up to 46°C/115°F ambient temperatures.
- Extremely small footprint with possible placement against a wall or in a corner. Available in multiple configurations.
- Premium connectivity with the Elektronikon Nano. Over-the-air updates ensure your G 15L-22 gets even better over time.



### **G 7L-15** **Industry-leading performance**

- Thanks to load/no load control, the compressor controller switches automatically to the optimum control mode for high, low and intermittent air consumption.
- Best-in-class performance, total reliability and low power consumption.

### **G 2-7** **Compact and efficient**

- Compared to piston compressors, the G 2-7 is quieter, cleaner, and more economical to own, while working longer hours.
- The high-efficiency IE3 motor allows for 24/7 operation, even in temperatures up to 46°C.
- The state-of-the-art rotary screw element minimizes energy use and operational costs.
- Thanks to the low-vibration belt system, the G 2-7 is extremely quiet.

# Quality air performance

## Full Feature with built-in dryer

The Full Feature version comes with a built-in refrigerant air dryer. It cools the compressed air and removes any moisture before it can enter your compressed air network. This prevents rust in your compressed air piping and avoids damage to your air tools.

## A choice of filters

To ensure your compressed air meets the quality requirements of a wide range of applications, different grade air filters can be selected:

- G 2-7: DD
- G 7L-15: DDx or PDx
- G 15L-22: DD or UD+

### G 2-7 FF

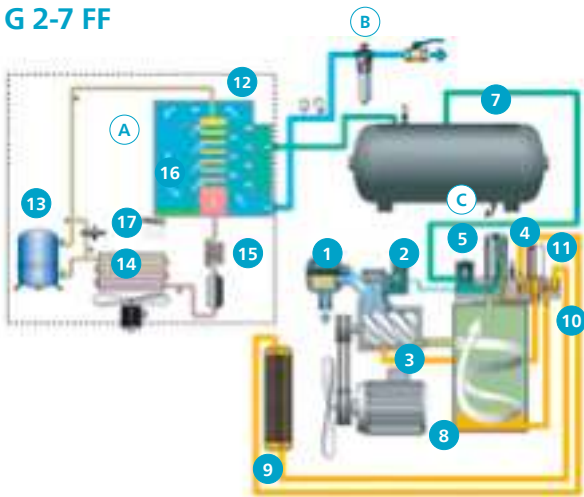

### G 7L-15 FF/G 15L-22 FF

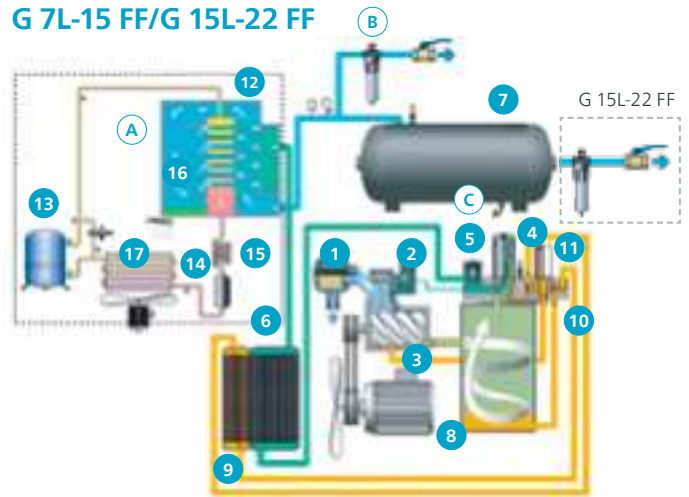

Intake air  
Air/oil mixture

Oil  
Wet air

Dry air  
Water

Refrigerant gas  
Refrigerant liquid

### Air Flow

- 1 Inlet air filter
- 2 Inlet valve
- 3 Compression element
- 4 Oil separator element
- 5 Minimum pressure valve
- 6 Aftercooler
- 7 Air receiver

### Oil Flow

- 8 Oil reservoir
- 9 Oil cooler
- 10 Thermostatic valve block
- 11 Oil filter

### Refrigerant Flow

- 12 Evaporator
- 13 Refrigerant compressor
- 14 Condenser
- 15 Capillary tube
- 16 Water separator
- 17 Electronic automatic drain

### Options

- (A) Full Feature
- (B) High-efficiency air filter
- (C) Electronic receiver drain

## Options

Available options	G 2-7	G 2-7 FF	G 7L-15	G 7L-15 FF	G 15L-22	G 15L-22 FF
Integrated aftercooler	O	O	O	⌘	⌘	⌘
Water separator (shipped loose)	-	-	O	⌘	O	⌘
Timer water drain on water separator (shipped loose)	-	-	O	-	-	-
Timer drain on air receiver (tank-mounted only)	O	O	O	O	-	⌘
Electronic no loss water drain on water separator (shipped loose)	-	-	O	⌘	O	O
Electronic no loss water drain on air receiver (tank-mounted only)	O	O	O	O	O	O
Integrated filter kit	-	O	-	O	-	O
500 l/125 gal air receiver (tank-mounted only)	O	O	O	O	⌘	⌘
Tropical thermostat	O	O	O	O	O	O
Anti-condensation kit	O	O	-	-	-	-
Food-grade oil	O	O	O	O	O	O
RSXD oil	O	O	O	O	O	O

⌘ Standard

O Optional

- Not available

# Technical specifications

Compressor type	Maximum working pressure		Capacity FAD			Installed motor power		Noise level**	Weight (kg/lbs)*	
	bar(e)	psi	l/s	m <sup>3</sup> /h	cfm	kW	hp		Pack	Full Feature
<b>50 Hz version</b>										
G 2	8	116	6.1	22.0	12.9	2.2	3	61	165/364	190/419
	10	145	4.9	17.6	10.4	2.2	3	61	165/364	190/419
G 3	8	116	7.9	28.4	16.7	3	4	61	170/375	195/430
	10	145	6.1	22.0	12.9	3	4	61	170/375	195/430
G 4	8	116	10.0	36.0	21.2	4	5.5	62	175/386	200/441
	10	145	8.6	31.0	18.2	4	5.5	62	175/386	200/441
G 5	8	116	14.8	53.3	31.4	5.5	7.5	65	185/408	210/463
	10	145	13.0	46.8	27.5	5.5	7.5	65	185/408	210/463
G 7	8	116	17.7	63.7	37.5	7.5	10	67	195/430	225/496
	10	145	16.4	59.0	34.7	7.5	10	67	195/430	225/496
G 7L	7.5	109	20.9	75.2	44.3	7.5	10	65	245/540	327/721
	10	145	18.2	65.5	38.6	7.5	10	65	245/540	327/721
	13	189	14.0	50.4	29.7	7.5	10	65	245/540	327/721
G 11	7.5	109	29.1	104.8	61.7	11	15	69	258/569	340/750
	10	145	24.1	86.8	51.1	11	15	69	258/569	340/750
	13	189	19.3	69.5	40.9	11	15	69	258/569	340/750
G 15	7.5	109	32.6	117.4	69.1	15	20	71	270/595	340/750
	10	145	29.1	104.8	61.7	15	20	71	270/595	340/750
	13	189	23.2	83.5	49.2	15	20	71	270/595	340/750
G 15L	7.5	109	42.5	153.0	90.1	15	20	67	537/1184	551/1215
	10	145	38.5	138.6	81.6	15	20	67	537/1184	551/1215
	13	189	31.2	112.3	66.1	15	20	67	537/1184	551/1215
G 18	7.5	109	52.1	187.6	110.4	18	25	69	545/1202	572/1261
	10	145	45.4	163.4	96.2	18	25	69	545/1202	572/1261
	13	189	38.5	138.6	81.6	18	25	69	545/1202	572/1261
G 22	7.5	109	62.0	223.2	131.4	22	30	70	561/1237	588/1296
	10	145	54.1	194.7	114.5	22	30	70	561/1237	588/1296
	13	189	46.4	167.1	98.3	22	30	70	561/1237	588/1296
<b>60 Hz version</b>										
G 2	8	116	6.2	22.3	13.1	2.2	3	61	180/397	205/452
	10	145	4.6	16.6	9.7	2.2	3	61	180/397	205/452
G 4	8	116	9.5	34.2	20.1	4	5.5	62	190/419	215/474
	10	145	8.5	30.6	18.0	4	5.5	62	190/419	215/474
G 5	8	116	13.8	49.7	29.2	5.5	7.5	65	200/441	225/496
	10	145	12.3	44.3	26.1	5.5	7.5	65	200/441	225/496
G 7	8	116	17.0	61.2	36.0	7.5	10	67	210/463	240/529
	10	145	16.1	58.0	34.1	7.5	10	67	210/463	240/529
G 7L	7.4	107	21.1	76.0	44.7	7.5	10	65	250/551	362/798
	9.1	132	18.5	66.6	39.2	7.5	10	65	250/551	362/798
	10.8	157	16.6	59.8	35.2	7.5	10	65	250/551	362/798
G 11	12.5	181	13.9	50.0	29.5	7.5	10	65	250/551	362/798
	7.4	107	28.6	103.0	60.6	11	15	69	255/562	365/805
	9.1	132	24.9	89.6	52.8	11	15	69	255/562	365/805
G 15	10.8	157	23.1	83.2	48.9	11	15	69	255/562	365/805
	12.5	181	19.1	68.8	40.5	11	15	69	255/562	365/805
	7.4	107	32.5	117.0	68.9	15	20	71	260/573	375/827
G 15L	9.1	132	29.8	107.3	63.1	15	20	71	260/573	375/827
	10.8	157	27.6	99.4	58.5	15	20	71	260/573	375/827
	12.5	181	23.1	83.3	49.0	15	20	71	260/573	375/827
G 18	7.4	107	44.0	158.4	93.2	15	20	67	537/1184	551/1215
	9.1	132	38.8	139.7	82.2	15	20	67	537/1184	551/1215
	10.8	157	37.0	133.2	78.4	15	20	67	537/1184	551/1215
G 22	12.6	182	32.7	117.7	69.3	15	20	67	537/1184	551/1215
	7.4	107	51.8	186.5	109.8	18	25	69	545/1202	572/1261
	9.1	132	46.9	168.8	99.4	18	25	69	545/1202	572/1261
G 22	10.8	157	43.3	155.9	91.7	18	25	69	545/1202	572/1261
	12.6	182	39.9	143.6	84.5	18	25	69	545/1202	572/1261
	7.4	107	60.5	217.8	128.2	22	30	70	561/1237	588/1296
G 22	9.1	132	53.7	193.3	113.8	22	30	70	561/1237	588/1296
	10.8	157	48.6	175.0	103.0	22	30	70	561/1237	588/1296
	12.6	182	46.0	165.6	97.5	22	30	70	561/1237	588/1296

\* Tank-mounted variant.

\*\* Floor-mounted variant.

Standard air receiver size, G 2-7: 200 l/53 gal & 2x90 l/24 gal, G 7L-15: 270 l/71 gal.

Unit performance measured according to ISO 1217, latest edition.

Mean noise level (pack variant) measured according to Pneurop/Cagi PN8NTC2 test code; tolerance 3 dB(A).

## Dimensions

### Floor-Mounted Models

	D (mm)	W (mm)	H (mm)
G 2-7 Pack	665	620	950
G 7L-15 Pack	720	855	1090
G 15L-22 Pack	833	1180	1220
G 2-7 Full Feature	665	1015	950
G 7L-15 Full Feature	720	1205	1090
G 15L-22 Full Feature	833	1280	1220

\* Dimensions of G 7L-15 tank-mounted are 650 x 1935 x 1463 mm (D x W x H) with a 500 l/125 gal vessel.

### Tank-Mounted Models

	D (mm)	W (mm)	H (mm)
G 2-7 Pack	665	1430	1260
G 2-7 Pack 2x90l tanks	780	1000	1295
G 7L-15 Pack	650	1603	1337
G 15L-22 Pack	833	1921	1832
G 2-7 Full Feature	665	1430	1260
G 2-7 Full Feature 2x90l tanks	780	1000	1295
G 7L-15 Full Feature	650	1603	1337
G 15L-22 Full Feature	833	1921	1832



ISO 9001 · ISO 14001  
OHSAS 18001

**Atlas Copco**

[atlascopco.com](http://atlascopco.com)

